

XACTROL[®]

VALVTECHNOLOGIES

Severe Service Control Valve ANSI 150-4500 1/2" - 36"



The Xactrol™ product group unites Valvtechnologies' zero-leakage technology with special designs that allow rotary modulating control. From Mark I design that features a characterized upstream seat, to the Mark III's precision engineered stacked disks, the Xactrol™ allows the customer to combine precise flow control with tight shutoff. The Xactrol™ is typically used in applications where minimum flow and relatively high differential pressures are required. It is available in sizes from 1/2" to 36" and in pressure classes ANSI 150 to 4500.

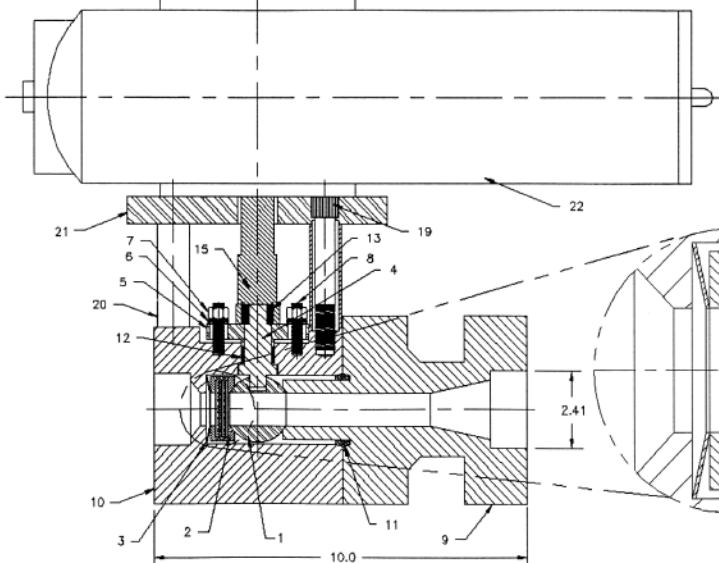
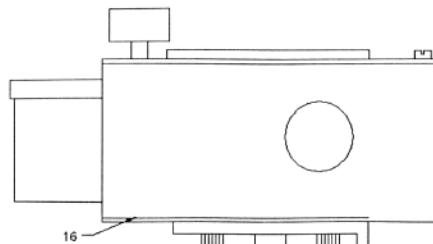

COMMON CONFIGURATIONS

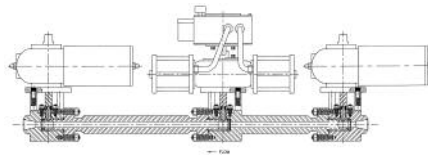

Xactrol Tandem Arrangement with Automated Isolation Valves

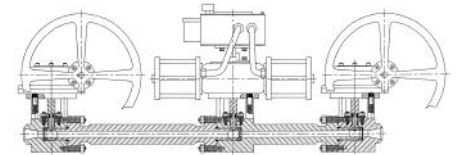

Xactrol Tandem Arrangement with Manual Isolation Valves

BILLS OF MATERIAL

ITEM	DESCRIPTION	MATERIAL	QTY.
1	BALL	410 S.S./RAM31	1*
2	UPSTREAM SEAT ASSY.	A182-F22/17-4	1*
3	BELLVILLE SPRING	INCONEL	1*
4	STEM	A638 GR. 660	1
5	GLAND	A182-F22/H.F.	1
6	GLAND LOAD SPRING	304 S.S.	24
7	GLAND NUT	A194Gr. B8M	4
8	GLAND STUD	A194Gr. B8M	4
9	END CAP	A182-F22/RAM31	1*
10	BODY	A182-F22	1
11	BODY GASKET	17-4 PH/GRAFOIL	3*
12	GLAND PACKING	GRAFOIL/316 S.S.	3*
13	KEY	STEEL	2
14	-	-	-
15	DRIVE SLEEVE	4130	1
16	POSITIONER	-	1
17	BODY STUD	A193 Gr. B8M	6
18	BODY NUT	A193 Gr. B8M	6
19	YOKE CAP SCREWS	A193 Gr. B7	4
20	YOKE POST	STEEL	4
21	YOKE PLATE	STEEL	1
22	PNEUMATIC ACTUATOR	-	1

* Recommended Spare Parts

Integral Seat, Four-Year Zero Leakage Guarantee

From simple minimum or normal flow control to full rangeability over a wide range of pressure drops and conditions, we have the solution for you.

Our Xactrol Mark I is designed for minimum or normal flow control conditions as is experienced in a large number of flow control applications. The Mark I comes with a variety of characterized upstream seats, which can be specifically engineered/ designed to suit your control needs.

The next step is the Mark II (see page 3). In addition to the normal flow conditions, the Mark II has a second flow port through the ball which is designed to handle your continuous minimum flow conditions.

For applications where very high pressure drops are required, we offer the Mark III (see page 3), which has a series of upstream pressure reducing plates. The plates will successfully reduce, stage by stage, the pressure in the system, which when combined with the full rangeability of control through the control ball and seat, will solve the toughest of control applications.

Regardless of the complexity of your control application, each of our customized engineered solutions, will be calibrated and tested on our state-of-the-art Flow Test Loop

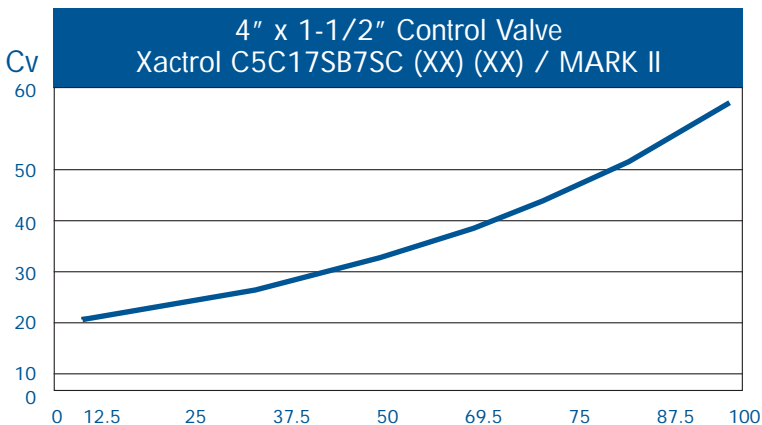
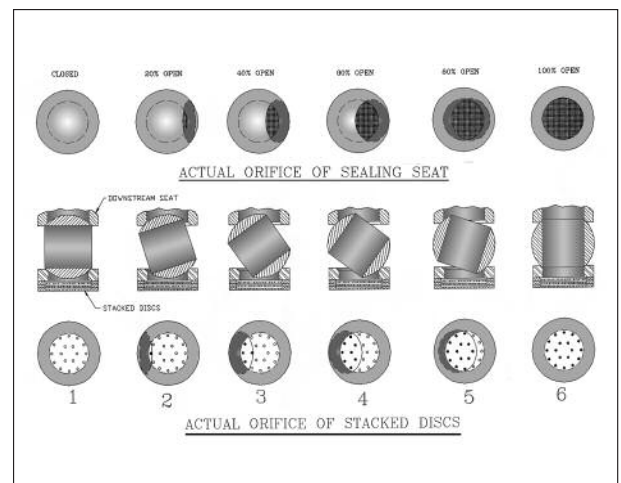
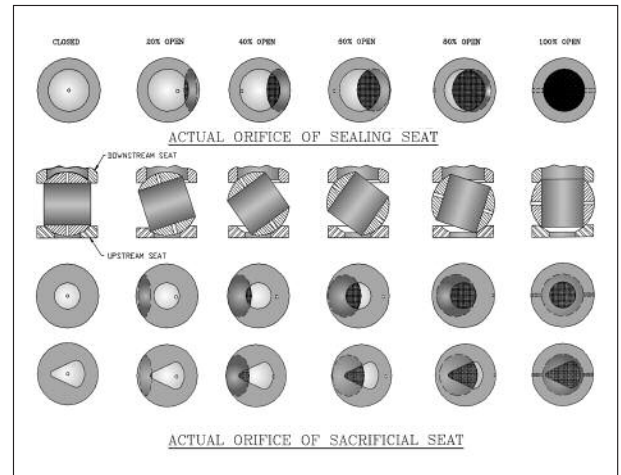
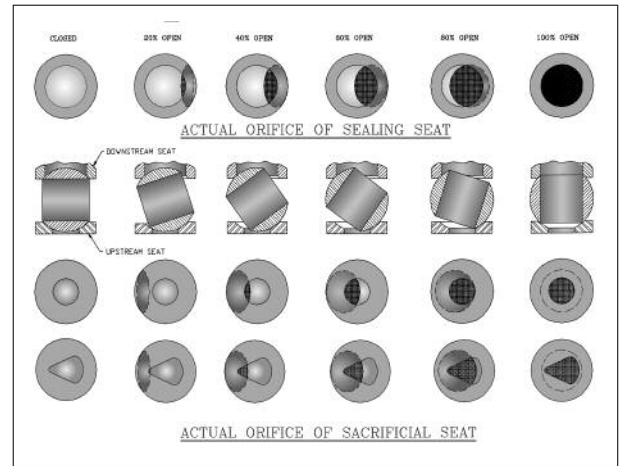

Each valve package will come complete with its own flow test curve to ensure complete reliability. Above graph is from an actual flow loop test, as supplied to the customer.

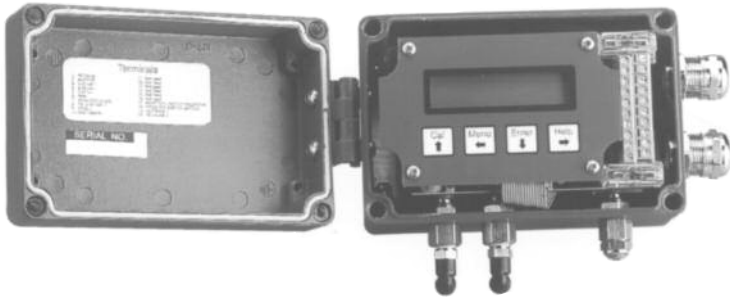

Intelligent Valve Controller

SPECIFICATIONS

EPP100 SR EEx " ib" for single acting actuators
EPP100 DA EEx " ib" for double acting actuators

2-WIRE CURRENT LOOP CONTROL

The control signal is a "real" 2-wire 4-20 mA current loop, with power and control signal in the same loop. If loop failure occurs, then the valve returns to failsafe position.

4-20 mA FEEDBACK SIGNAL

ACTUATORS

The controller is available for double acting and spring return pneumatic actuators.

AUTO CALIBRATION

The self calibration routine sets all the basic settings and measures the actuator size for optimum valve control and fast feedback loop.

LOW AIR CONSUMPTION

Air is only used when it is needed providing significant savings in instrument air costs.

VALVE FLOW CHARACTERISTICS

Choice of integrated standard valve curve characteristics for ball control valves (equal percentage).

MANUAL SETPOINT

In service situations the setpoint can be manually chosen from the user menu.

FOUR BUTTON CONTROL PANEL

The four (4) button control panel makes each command sequence simple and easy to follow.

MECHANICAL STABILITY

The compact design with few moving parts is insensitive to environmental influences providing a high degree of immunity from failure.

DIGITAL COMMUNICATION

Up to thirty two (32) units can be linked via RS 485 communication interface to a PC or Laptop Computer for configuration and remote control.

DIGITAL LCD DISPLAY

The two (2) lines of sixteen (16) digit alphanumeric display.

POWER FAILURE OPTIONS

If power fails the controller will close the actuator. When power returns the controller will restart and regulate again with no loss of data and configuration.

DIAGNOSTIC ALARMS

Internal diagnostic alarm is activated in the event of air failure or if the control valve does not operate and the local LCD display will show an error message.

Technical Specifications

Control Signal	2 wire 4 - 20 mA, 18-24V
Feedback Signal	4-20 mA, passive transmitter
Operating Temp Range	21.6 -183.6 F°
Hysteresis	0.8%
Linearity	<1%
Sensitivity	0.4%
Air Supply	0 - 100 psi (0 - 7 Bar)
Air Consumption	@ 0
Air Flow	50 l/min
Air Filtering	<30 um
Air Entry	1/4" NPT
Electrical Entry	2 x M20, 1.5 mm2
Dimensions	L x B x H = 5.9 X 5.9 X 3.94"
Housing	Stainless steel 316 ss
Ingress Protection	IP 65
Weight	4.185 lbs.
Maximum Rotation	300°

Dynamics of Mark III Xactrol Control Valve

Upstream pressure reducing plates are stacked so maximum flow (pressure) travels through plate A (Fig. 3) then splits and pressure continues to be reduced as flow proceeds to follow tortuous 90° paths through succeeding holes in various stacked pressure reducing plates, see plates B, C & D (Fig. 3).

Multi-stage pressure reducing plates are positioned such that the diverging streams through the various plates actually collide with each other – greatly reducing their energy – before entering the next plate (Fig. 1).

Pressure reduction is at the upstream side of the valve, thus reducing the torque required to open and close the valve.

Downstream sealing face is protected from flow, thus offering repeatable tight shut-off.

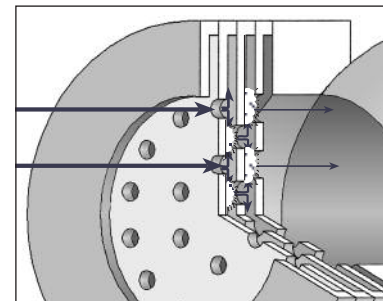

Figure 1

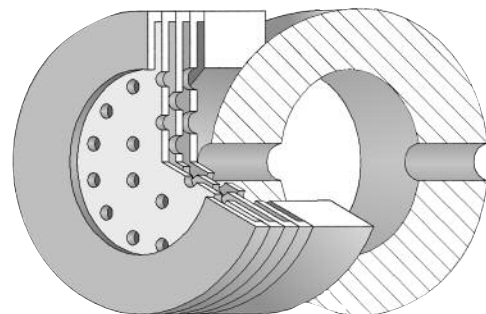

Figure 2

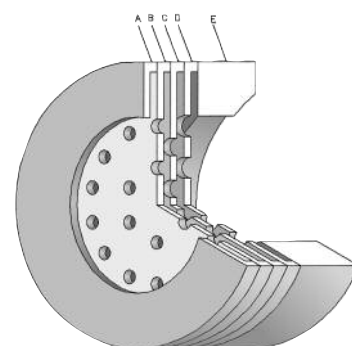

Figure 3



Worldwide Office Locations

Headquarters & Manufacturing

ValvTechnologies, Inc.
5904 Bingle Road
Houston, Texas 77092 U.S.A.
Telephone +1 713 860 0400
Fax +1 713 860 0499
info@valv.com

To locate a distributor or satellite office near you, visit us online at: www.valv.com

To contact sales anywhere in the world, email sales@valv.com

Peru

Lima
peru@valv.com

Brazil

São Paulo
brazil@valv.com

United Kingdom

Stockton-on-Tees
europa@valv.com

Australia

Brisbane
australia@valv.com

China

Shanghai
china@valv.com

China

Chengdu
china@valv.com

China

Beijing
china@valv.com

Eastern Europe

Warsaw
poland@valv.com

Middle East

Dubai
middle.east@valv.com

India

Chennai
india@valv.com

Japan/Korea

Seoul
korea@valv.com

Spain

Madrid
spain@valv.com